

PRODUCT DATA SHEET

PENSIL® PEN300 Silicone Sealant

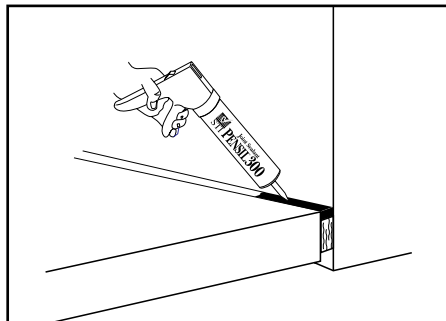

1. PRODUCT DESCRIPTION

Pencil® Silicone Sealants are one-part neutral curing silicone sealants exhibiting superior performance in applications where sealing apertures in walls and floors are needed to control the spread of fire, smoke, toxic gasses, and water during fire conditions.

Pencil® Silicone Sealants react with atmospheric moisture to form a tough durable seal that will adhere to most building substrates without the use of primers. Pencil® products do not contain asbestos or PCBs.

BASIC USES:

Pencil® 300 Firestop Sealant is designed for use in Underwriters Laboratories (UL) classified firestop systems. This material can also insulate openings to prevent damage from occasional water spillage and dust penetration in sensitive areas.

Pencil® 300 Firestop Sealant is available in non slump (PEN300) and self-leveling (PEN300 SL) grades and may also be used to seal vertical and horizontal joints between metals, masonry, concrete and other common construction materials. Pencil® 300 is specially designed for use in static or dynamic joints. The low modulus characteristic minimizes strain on the substrate surface and the elastomeric quality allows excellent recovery from extension and compression cycling.

2. APPLICATIONS

Pencil® 300 is used to seal through-penetrations involving non-combustible penetrants, electrical, data, or telephone cables, construction gaps, expansion joints, curtain wall safing applications, and top-of-wall joints.

3. PHYSICAL PROPERTIES

See Table A.

4. PERFORMANCE

Pencil® Silicone Sealants are the basis for systems that meet the exacting criteria of ASTM E814, (UL 1479), ASTM E1966 (UL 2079), ASTM 1399, as well as the time-temperature requirements of ASTM E119 (UL 263). Pencil® 300 Sealant is ASTM C920 compliant. Systems have been tested with ratings up to 4 hours.

FILL, VOID OR CAVITY MATERIALS
CLASSIFIED BY UNDERWRITERS
LABORATORIES INC. ®
FOR USE IN JOINT SYSTEMS &
THROUGH-PENETRATION
FIRESTOP SYSTEMS.

3L73
31X5

SEE UL FIRE RESISTANCE DIRECTORY

FILL, VOID, OR CAVITY MATERIALS CLASSIFIED BY
UNDERWRITERS LABORATORIES INC.
FOR USE IN JOINT SYSTEMS &
THROUGH-PENETRATION
FIRESTOP SYSTEMS.

SEE UL DIRECTORY OF PRODUCTS CERTIFIED FOR
CANADA AND
UL FIRE RESISTANCE DIRECTORY

FEATURES

- **Low Modulus** allows up to $\pm 50\%$ movement in joints.
- **Auto Bonding** allows fresh sealant to adhere to cured sealant.
- **Excellent Water Resistance** for water-tight sealing.
- **Ozone and UV Resistant** for excellent weathering ability and long service life.
- **Excellent Chemical Resistance** protects in polluted or corrosive atmospheres.
- **Excellent Adhesion** to most building substrates.
- **Excellent Smoke Seal**
- **Neutral Cure**

5. SPECIFICATIONS

The firestopping sealant shall be a one-part, neutral curing silicone sealant. The sealant shall be completely water resistant and shall contain neither solvents nor inorganic fibers of any kind. The through-penetration firestop sealant shall allow movement of $+25\%$ and shall be UL Classified and tested to the requirements of ASTM E814 (UL1479). The firestop joint sealant shall allow movement up to $\pm 50\%$ and shall be UL Classified and tested to the requirements of UL2079 (ASTM E1966).

SPECIFIED DIVISIONS

DIV. 7	07840	Through-Penetration Firestopping
DIV. 13	13900	Special Construction Fire Suppression & Supervisory Systems
DIV. 15	15250	Mechanical Insulation – Fire Protection
DIV. 16	16050	Basic Electrical Materials & Methods

**Table A:
PHYSICAL PROPERTIES**

Color	Concrete
Flame Spread^A	5
Smoke Development^A	45
In Service Temp	≤ 350°F (177°C)
Hardness Shore^A ASTM D2240	25
Tensile Strength ASTM D412	270
Peel Strength ASTM C794-80	55 ppi
Movement Capability	
ASTM C719	± 50%
AC30†	± 35%
Stress @ 50% Extension	
1/2" x 1/2" Bead	35 lbs/in
Tooling Time (Minutes)	30
Tack Free Time (Hours), ASTM C619	5 - 9
Sag; Slump (NS Grade) ASTM C639	0.1"
Ozone & UV Resistance	
(Weatherometer Twin Arc)	Excellent
Storage Warranty Period **	12 months
VOC Content	.231 lb/gal (27.0 g/L)

^A ASTM E84 (UL723) @14% coverage
^{**} From date of shipment if stored in original unopened container at 80°F (27°C).
[†] 500 Cycles as per UL2079, AC30 (ICBO), and ASTM E1399

6. INSTALLATION INSTRUCTIONS

THROUGH-PENETRATION FIRESTOPPING

Pensil® 300 Sealant is approved for a variety of through-penetration firestop applications. Some typical installations have been illustrated here to assist in the selection of the proper installation method. Space limitations preclude highly detailed information pertaining to individual application systems. Please consult the STI referenced drawing, the STI Product and Application Guide, as well as the UL Fire Resistance Directory for additional information.

Fig. 1: METALLIC PIPE PENETRATIONS

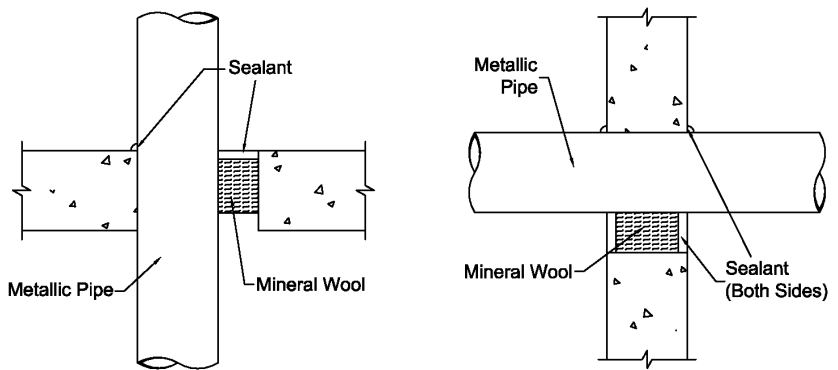

UL SYSTEM C-AJ-1198
 F Rating: 3 hr • T Rating: 0 hr
 Steel or Iron Pipe: 24", Copper Pipe: 4"
 Annulus: Point Contact to 2 1/4" • Sealant Depth: 1/2"
 Forming Material: Nom 4 pcf Mineral Wool
 Tightly Packed to a 3" Depth.

Preparation: All surfaces to receive Pensil® sealant must be sound, dry, frost-free, and free of bond-breaking contaminants and loose material. Wire brush contact surfaces or wipe with a suitable solvent as necessary to remove any contaminants. Mask all areas where adhesion is undesirable. Do not apply to wet or frost covered surfaces.

Forming: Some installations may require forming as either an integral part of the system or as an option to facilitate installation. In systems where forming is required, mineral wool batting (4 lb./cu. ft. or 64 kg/m³ density) is recommended for use in through-penetrations. Where forming materials are required, cut oversized to allow for tight packing. Position forming material as required for the proper depth of fill material.

Fill Material: Pensil® 300 Sealants may be installed by caulking using a standard caulking gun or from bulk containers using a bulk loading caulk gun, or by manually troweling using a mason's trowel or putty

knife. If the sealant tends to pull back from a surface, clean the surface using the methods described above and reapply. Install sealant to required depth. Work sealant into all areas exercising care to eliminate voids or seams. In gypsum wall board penetrations, crown sealant a minimum of 1/4" (7 mm) from penetrant to wallboard surface at a point approx. 1/2" (13 mm) or more from opening.

For applications involving cable bundles, spread cables sufficiently to ensure that sealant completely envelops all cables and totally fills all voids to the required depth.

Smoke Sealing: Pensil® Silicone Sealants make an excellent smoke seal. Apply at gaps and seams to prevent the passage of smoke. Some SpecSeal Firestop Collar designs utilize Pensil® Silicone Sealant as the smoke seal. Consult the STI Product and Application Guide for further information.

CONSTRUCTION JOINTS

Pensil® 300 Sealants are approved for sealing

Fig. 2: MISCELLANEOUS METALLIC PIPE & CABLE PENETRATIONS

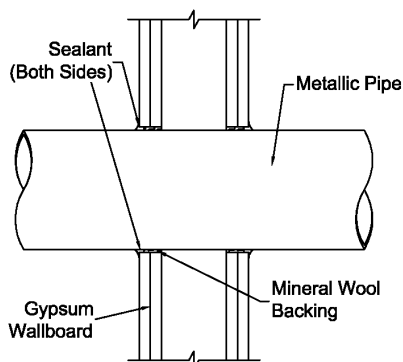

UL SYSTEM W-L-1033
 F Rating: 2 hr • T Rating: 0
 Steel Pipe: 6", Copper Pipe or Tubing: 4"
 Sealant Depth: 1/4" (within annulus) + 1/4" Crown
 Forming Material: Nom 4 pcf Mineral Wool
 Tightly Packed to a 1" Depth.

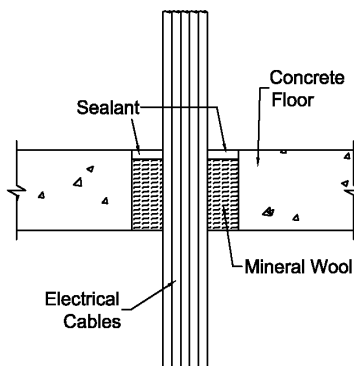

UL SYSTEM C-AJ-3023
 F Rating: 3 hr • T Rating: 1/2 hr
 Electrical, Telephone, or Data Cables
 Annulus: 1/2" to 1" • Sealant Depth: 1/2"
 Forming Material: Nom 8 pcf Mineral Wool
 Tightly Packed to a 4" Depth.

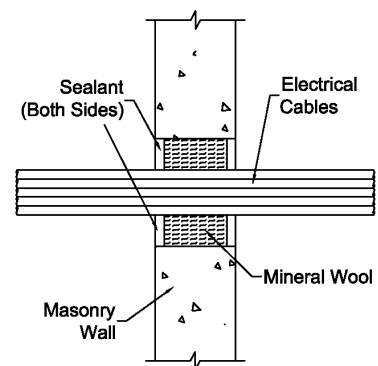

Table B: SEALANT REQUIREMENTS IN CUBIC INCHES PER 1/4 INCH OF INSTALLED DEPTH*

Pipe Size		Diameter of Opening (in.)											
Trade Pipe Size	Pipe O.D.	1.5	2.0	3.0	4.0	5.0	6.0	7.0	8.0	10	12	14	26
0.5"	0.840	0.3	0.6	1.6	3.0	4.8	6.9	9.5	12.4	19.5	28.1	38.3	132.6
1"	1.315	0.1	0.4	1.4	2.8	4.6	6.7	9.3	12.2	19.3	27.9	38.1	132.4
1.5"	1.900			1.1	2.4	4.2	6.4	8.9	11.9	18.9	27.6	37.8	132.0
2"	2.375			0.7	2.0	3.8	6.0	8.5	11.5	18.5	27.2	37.4	131.6
2.5"	2.875			0.1	1.5	3.3	5.4	8.0	10.9	18.0	26.7	36.9	131.1
3"	3.500				0.7	2.5	4.7	7.2	10.2	17.2	25.9	36.1	130.3
3.5"	4.000					1.8	3.9	6.5	9.4	16.5	25.1	35.3	129.6
4"	4.500					0.8	3.0	5.6	8.5	15.6	24.2	34.4	128.7
6"	6.625							1.1	4.0	11.1	19.7	29.9	124.2
8"	8.625									4.9	13.6	23.8	118.0
10"	10.750										5.6	15.8	110.0
12"	12.750											6.6	100.8
24"	24.000												19.6

***Different Sealant Depth?**
 1/2" Multiply by 2
 5/8" Multiply by 2.5
 1" Multiply by 4
 1-1/4" Multiply by 5

IMPORTANT NOTE: This table is for estimation purposes only. Consult UL Fire Resistance Directory or STI Product & Application Guide for specific installation requirements and limitations
 NOTE: Metric table is available.

a variety of construction joint applications. FIG. 3 illustrates some common joint designs in masonry construction. Space limitations preclude highly detailed information pertaining to individual application systems. Please consult the STI referenced drawing, the STI Product and Application Guide, as well as the UL® Fire Resistance Directory for additional information.

Joint Designs: Joints firestopped with Pensil® 300 will accommodate ±50% movement providing the joint is 1/2" (13 mm) or wider. If the joint is less than 1/2" (13 mm) wide, the movement should be limited to ±25% of the actual joint width.

The dimensions of expansion joints and similar applications change daily as a result of solar heat gain, positive and negative buffeting from wind forces, and throughout the year because of seasonal changes.

If the firestop cannot be installed when the joint is at its midpoint of dimensional extremes, the joint width should be designed at twice the anticipated movement, plus the dimensional amount the joint deviates from the midpoint at the time of sealant installation. For example, if Pensil® 300 is to be installed in an expansion joint and movement is expected to be ±3/8" (10 mm) and the joint is not at its midpoint, the

joint width should be 3/4" (19 mm) plus any deviation from the joint midpoint.

Lap shear joints should have a bead width that is equal to, or greater than, the total anticipated movement.

IMPORTANT NOTE: Joint designs incorporating Pensil® Silicone Sealants are not designed to be load bearing or exposed to traffic. Joint seals must be protected by suitable metallic cover plates in exposed floor areas.

Preparatory Work: Clean all concrete, masonry and stone joints of all contaminants and impurities. Concrete laitance, all old sealants and other surface treatments and protective coatings are examples of materials that must be removed from the joint surfaces to obtain proper sealant adhesion. Porous substrates should be cleaned where necessary by grinding, saw cutting, blast cleaning (sand or water), mechanical abrading or a combination of these methods are required to provide a sound, clean surface for sealant application. Dust, loose particles, etc. should be blown out of the joint with oil-free compressed air or vacuum cleaned.

Priming: Pensil® Silicone Sealants have primer less adhesion to many construction materials including untreated or uncoated concrete. Jobsite trial applications are

recommended if contact surfaces are in any way questionable. Application of SCP3154 primer may remedy adhesion difficulties for questionable concrete surfaces.

Masking: The use of masking tape is recommended where appropriate to insure a neat job and to protect adjoining surfaces. Do not allow masking tape to touch clean surfaces to which the silicone sealant is to adhere. Masking tape should be removed immediately after the finish tooling of the Pensil® Firestop Sealant.

Forming: Some installations may require forming as either an integral part of the system or as an option to facilitate installation. In systems where forming is required, mineral wool batting (4 lb./cu. ft. or 64 kg/m³ density), or other approved backer materials are recommended.

To calculate the volume of forming material required for the joint, add 20 - 25% to the volume required for the joint at its greatest extension (for dynamic joints) or widest width (for static joints). Where required, cut forming material oversize to allow for tight packing. Recess forming materials as required for application of the proper depth of fill material.

Fill Material: Apply Pensil 300 Firestop Sealant

Fig. 3: TYPICAL JOINT INSTALLATION METHODS

FOD-5005 12/99

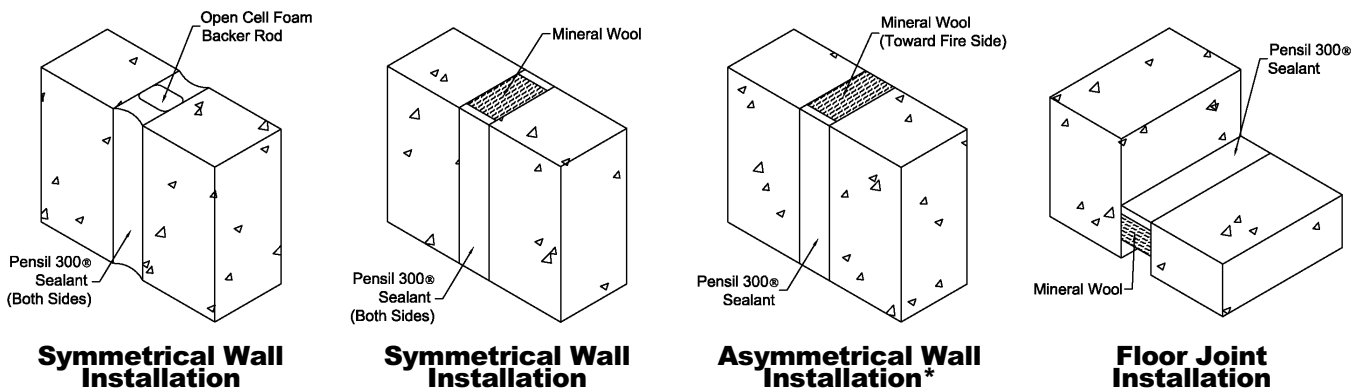

*Rated one side only.



in a continuous operation, horizontally in one direction and vertically from the bottom to the top of the joint opening. A positive pressure adequate to properly fill and seal the joint width should be employed. Tool or strike Pensil Firestop Sealant with light pressure to spread the material against the backup material and the joint surface. The lightweight consistency of Pensil 300 Firestop Sealant responds easily to light tooling pressure and facilitates void free placement. On porous surfaces the excess sealant should be allowed to progress through the initial cure or setup. It should then be removed by abrasion or other mechanical means.

7. MAINTENANCE

Inspection: Installations should be inspected periodically for subsequent damage. Any damage should be repaired using SpecSeal® products per the original approved design. Cut away damaged material and reapply sealant as required. NOTE: New penetrants of a different nature than the original design may require a totally new firestop design or extensive modifications to the existing design. Reseal all openings as per the requirements of the modified design.

8. TECHNICAL SERVICE

Specified Technologies Inc. provides toll free technical support to assist in product selection and appropriate installation design. UL Systems, Material Safety Data Sheets and other technical information is available at the Technical Library at www.stifirestop.com.

9. PRECAUTIONARY INFORMATION

Avoid contact with eyes. Uncured product may irritate eyes on contact. Use only in well ventilated areas. To clean areas of skin contact, wipe off uncured material with a dry cloth or paper towel prior to washing. Waterless hand cleaners are particularly effective while sealant is uncured. Consult Material Safety Data Sheet for additional information on the safe handling and disposal of this material.

10. AVAILABILITY

Pensil® Silicone Sealants are available from authorized STI distributors. Consult factory for the names and locations of the nearest sales representatives or distributors. Available packages and additional SpecSeal® Products are listed below.

**Table C: PRODUCT ESTIMATION INFORMATION
(Construction Joints)**

JOINT	PER 1/4" INSTALLED DEPTH			PER 1/2" INSTALLED DEPTH			PER 1" INSTALLED DEPTH		
	WIDTH	CU IN/FT	FT/GAL	GAL/100 FT	CU IN/FT	FT/GAL	GAL/100 FT	CU IN/FT	FT/GAL
0.5	1.5	154	.65	3	77.0	1.3	6	38.5	2.6
0.75	2.3	102	.95	4.5	51.3	1.9	9	25.7	3.9
1.0	3.0	77	1.3	6.0	38.5	2.6	12	19.3	5.2
1.5	4.5	51	2	9.0	25.7	3.9	18	12.8	7.8
2.0	6.0	38	2.6	12	19.3	5.2	24	9.6	10.4
2.5	8.0	31	3.3	15	15.4	6.5	30	7.7	13.0
3.0	9.0	25	3.9	18	12.8	7.8	36	6.4	15.6
3.5	11	22	4.6	21	11.0	9.1	42	5.5	18.2
4.0	12	19	5.2	24	9.6	10.4	48	4.8	20.8
5.0	15	15	6.5	30	7.7	13.0	60	3.9	26.0
6.0	18	12	7.8	36	6.4	15.6	72	3.2	31.2

TABLE D: ORDERING INFORMATION

CAT. NO. DESCRIPTION

- PEN300 10.3 oz Tube (304 ml) 18.5 cu. in.
- PEN305 5 Gal. Pail (19.0 liters) 1,155 cu. in.
- PEN305SL Self-Leveling 5 Gal. Pail (19.0 liters) 1,155 cu. in.

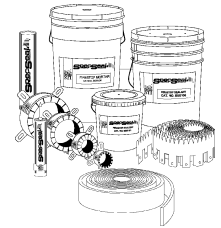

Additional SpecSeal Products...

SSS Series Sealant

The industry's most versatile sealant provides the firestopping solutions for a wide range of combustible and noncombustible applications. Water-based intumescent sealant expands up to 8x!

SSP Firestop Putty

Available both in bar form and in pads, putty provides easy retrofit for through-penetrations and economical protection for electrical boxes.

SSB Firestop Pillows

Durable, monolithic pillows for installations requiring quick and easy retrofitting. Systems designed for pipes, cables and cable tray in all types of construction!

Firestop Mortar

Lightweight, versatile and economical! The best choice for large or complex installations.

Intumescent Wrap Strips

Three grades of intumescent wrap strips provide an unmatched combination of flexibility, economy, and expansion (up to 30X). Systems for plastic pipes including FR Polypropylene up to 8" trade size!

Elastomeric Joint Seals

Economical products for sealing construction joints. Choose caulk or spray applied products tested to UL2079.

Molded Firestop Collars

Easy to install, economical protection for ABS and PVC pipes (both solid and foam core) as well as CPVC, PVDF, and FRPP. Collars available up to 6" trade size.

CITY OF NEW YORK MEA 12-93M

Important Notice: All statements, technical information, and recommendations contained herein are based upon testing believed to be reliable, but the accuracy and completeness thereof is not guaranteed.

WARRANTY: Specified Technologies Inc. manufactures its goods in a manner to be free of defects. Should any defect occur in its goods (within one year), Specified Technologies Inc., upon prompt notification, will at its option, exchange or repair the goods or refund the purchase price.

Limitations and Exclusions: THIS WARRANTY IS IN LIEU OF ALL OTHER REPRESENTATIONS EXPRESSED OR IMPLIED (INCLUDING THE IMPLIED WARRANTIES OF MERCHANTABILITY OR FITNESS FOR USE) AND UNDER NO CIRCUMSTANCES SHALL SPECIFIED TECHNOLOGIES INC. BE RESPONSIBLE FOR ANY INCIDENTAL OR CONSEQUENTIAL PROPERTY DAMAGE OR LOSSES. PRIOR TO USE, THE USER SHALL DETERMINE THE SUITABILITY OF THE PRODUCT FOR ITS INTENDED USE, AND THE USER ASSUMES ALL RISKS AND LIABILITY FOR SUBSEQUENT USE.

No statement or recommendation not contained herein shall have any force or effect unless in an agreement signed by officers of seller and manufacturer.

MADE IN THE USA – COPYRIGHT © 2004 SPECIFIED TECHNOLOGIES, INC.



Specified Technologies Inc.

200 Evans Way • Somerville, NJ 08876
Phone: (800) 992-1180 • Fax: (908) 526-9623
STI on the WEB: www.stifirestop.com

